



Innovative Technology

INTELLIGENCE IN VALIDATION

Spectral Payout

“Unrivalled mixed denomination recycler”



- Superior mixed denomination banknote recycler
- 100% note image capture – highest spectral coverage
- Eliminates coin starvation
- Reduce operational collection costs



FEATURES

- 80 note 'true' mixed denomination recycler - can store all denominations from a given currency
- Full spectral imaging sensors validate the authenticity of notes
- 99% first time acceptance of new and street grade notes
- Accepts notes up to 85mm wide & recycles notes up to 82mm wide
- Notes are transferable to the cashbox for easy collection
- Improved serviceability for easy maintenance, internal memory for data logging and free firmware updates



BENEFITS

- Eliminates coin starvation & reduces the coin float levels required to keep machines operational
- Exceptional genuine note detection & protection against fraudulent notes
- Faster note processing and recycling, maximise cash efficiency
- One product suitable for global applications
- Reduces operator collection costs
- Best in class performance & future proof your investment

Technical Specification

Power

Requirements: 12V/24V
Standby: 400mA
Running: 3A
Peak: 5.5A

Protocols

SSP
ccTalk

Interfaces

USB option
Open collector
RS232

Cashbox Options

500 notes
1000 notes

Recycler Capacity

Up to 80 mixed notes

Bezel Options

82/85mm width
Metal bezel
Various illumination options

Note Dimensions

Accepts: Width: 60-85mm
Length: 115-170mm
Recycles: Width: 60-82mm

MCBF

100,000

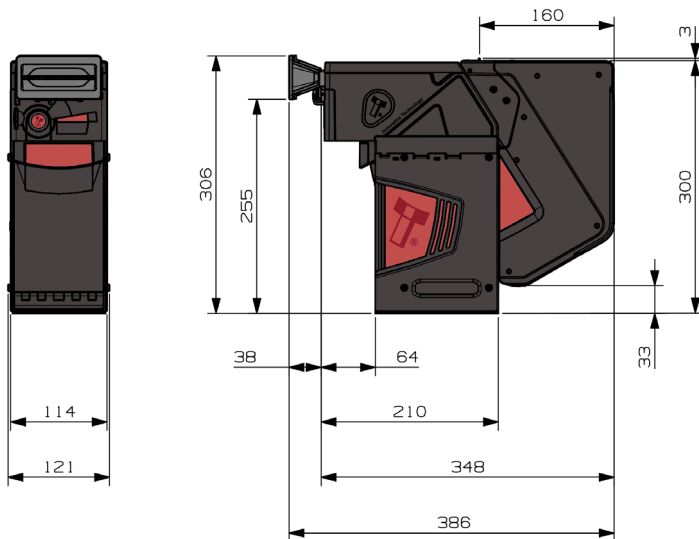

- Weight: 5.5kg

**VIEW MORE
NOTE HANDLING
PRODUCTS >>**



Find Us

Head Office

REPTECH SAC
Av. La Molina #2830, Of. S-16,
Distrito de la Molina, Lima-Peru



Telephone

+51 956 201 108



Email

ventas1@reptechperu.com